



12.4 GHz N LATCHING S.P.6 T. SWITCH

OPTIONS : INDICATOR /SELF CUT-OFF /AUTO RESET /SUPP.DIODES

R F CHARACTERISTICS

NUMBER OF WAYS : 6
FREQUENCY RANGE : 0 - 12.4 GHz
IMPEDANCE : 50 Ohms

FREQUENCY (GHz)	0 - 3	3 - 8	8 -12.4
V.S.W.R <=	1.20	1.35	1.50
INSERT. LOSS <=	0.20 dB	0.35 dB	0.50 dB
ISOLATION >=	80 dB	70 dB	60 dB
AVER. POWER (*)	400 W	250 W	200 W

ELECTRICAL CHARACTERISTICS

ACTUATOR : LATCHING
NOMINAL CURRENT AT 25° C (±10%) : 375 mA
ACTUATOR VOLTAGE (Vcc) : 28V (24 to 30V) / NEGATIVE COMMON
TERMINALS : solder pins (250°C max./30 sec.)
INDICATOR RATING : 1 W / 30 V / 100 mA
SELF CUT-OFF TIME : 40 ms < CT < 120 ms

MECHANICAL CHARACTERISTICS

CONNECTORS : N female per MIL C 39012
LIFE : 2.000.000 cycles per position
SWITCHING TIME (nominal voltage;25° C) : < 40 ms
CONSTRUCTION : splashproof
WEIGHT : < 460 g

ENVIRONMENTAL CHARACTERISTICS

OPERATING TEMPERATURE RANGE (°C) : -40 , +85
STORAGE TEMPERATURE RANGE (°C) : -55 , +85

(* : average power at 25° C per RF path)

4112-9212 This information is given as an indication. In the continual goal to improve our products, we reserve the right to make any modifications judged necessary

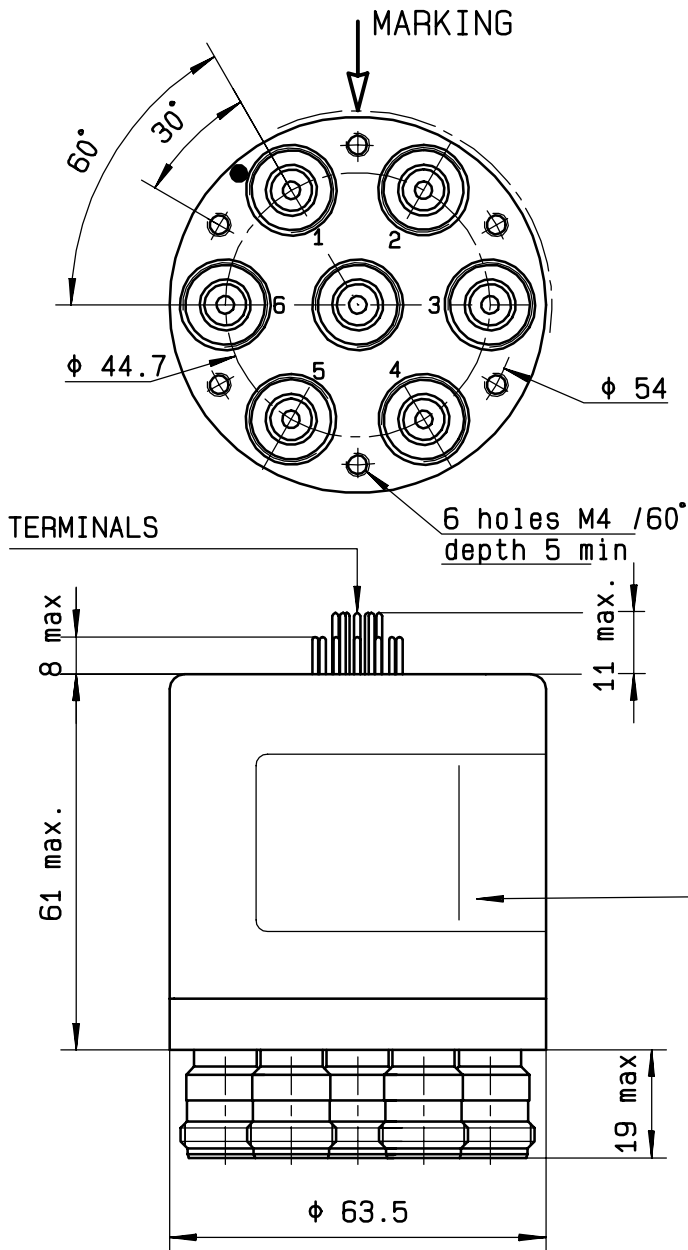

Voltage	RF continuity	Ind.
-C +1	IN ↔ 1	D.E
-C +2	IN ↔ 2	D.F
-C +3	IN ↔ 3	D.G
-C +4	IN ↔ 4	D.H
-C +5	IN ↔ 5	D.I
-C +6	IN ↔ 6	D.J

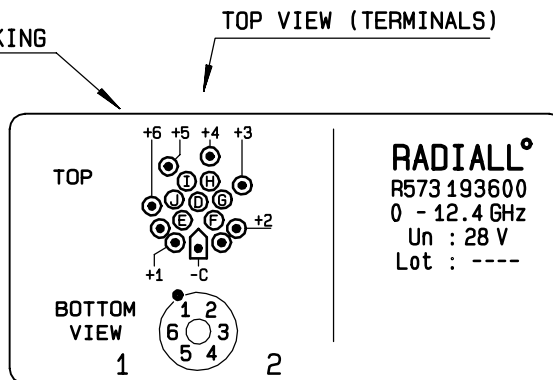

SCHEMATIC DIAGRAM

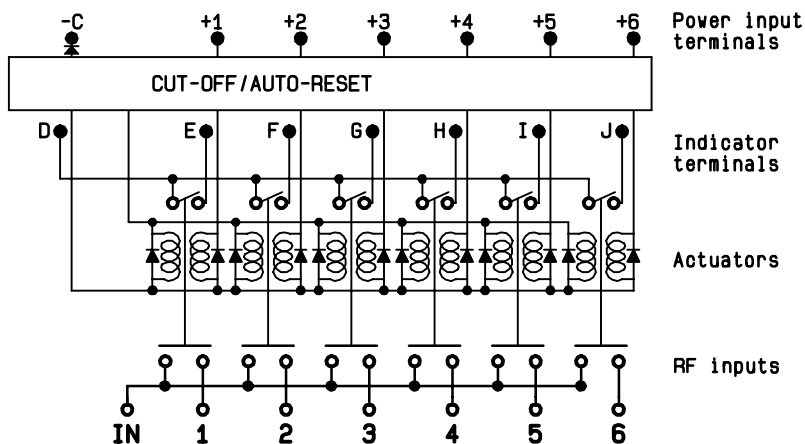

This information is given as an indication. In the continual goal to improve our products, we reserve the right to make any modifications judged necessary

4113-9212